

PISTON™ PRO X

TWO BIKE

ASSEMBLY



ASSEMBLY VIDEO

URL



HOW TO USE VIDEO

URL

Parts



(1) Foot Lever



(2) Key

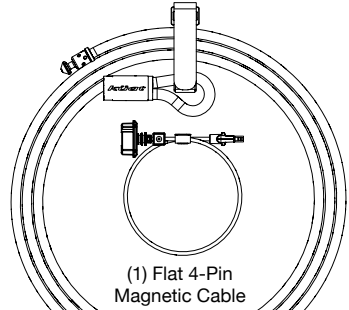

(1) Flat 4-Pin
Magnetic Cable

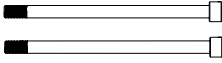

(2) M10 x 165 Bolt



(2) M10 Nut



(1) M6 x 45



(1) M6 Washer

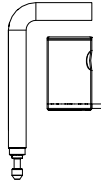

(1) Hitch Pin
(1) Hitch Lock

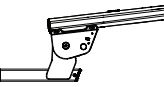

(1) Centerbeam



(4) Tray

Tools

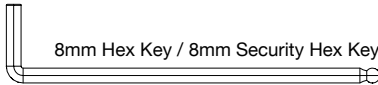

8mm Hex Key / 8mm Security Hex Key

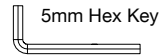

5mm Hex Key

1 We recommend inserting centerbeam assembly into a hitch for a greatly improved assembly experience.

2 Keep your struts clean! Just like your shifter and derailleur, dirt, dust, and grime can work themselves into the mechanism resulting in sub-par performance. Periodically run a cloth around each Piston™ tube to keep your rack looking good and functioning smoothly.

3 Assembly of the 2" Receiver and 1.25" Receiver versions of the Piston™ are virtually identical. Minor differences in the hitch installation processes are shown.

Hitch Installation

- 1 Insert centerbeam assembly into your hitch receiver.

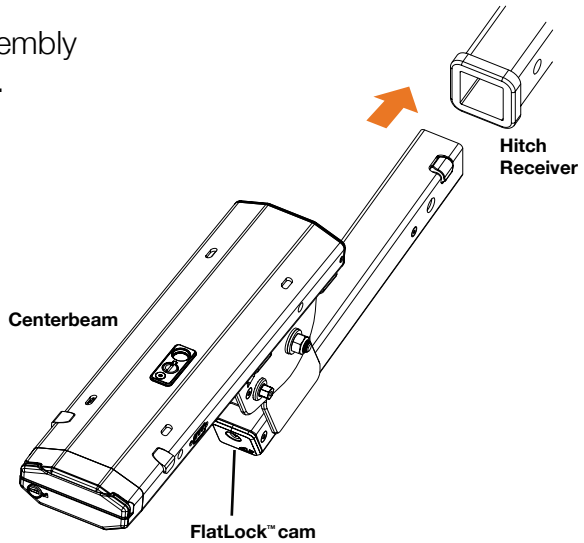

- 2 Find and unlock the 8mm security hex key found at the front of the centerbeam assembly to tighten FlatLock™ cam and secure Piston™ in your hitch.

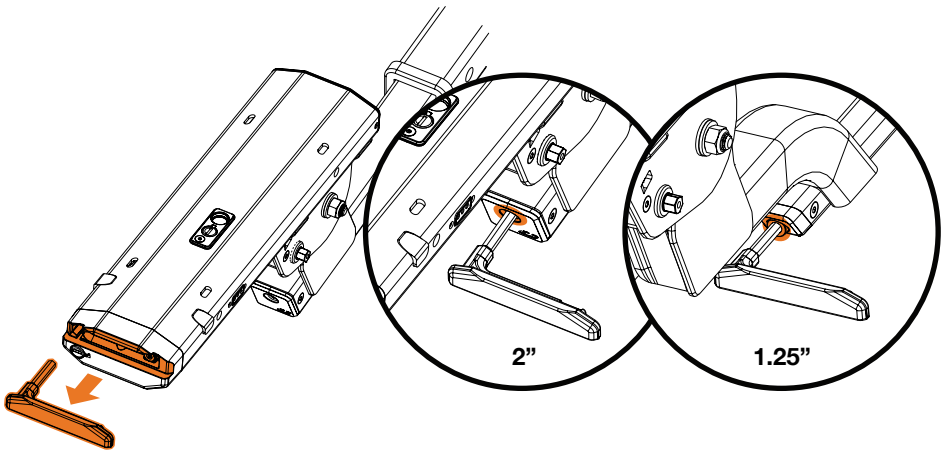

- 3 Fully tighten FlatLock™ cam to secure centerbeam in hitch receiver.

 Remember to reinstall and secure security hex with provided key.

Foot Lever Assembly

- 1 Slide foot lever into position on centerbeam assembly, installing M6 Washer and M6x45 bolt using the provided 5mm hex key.

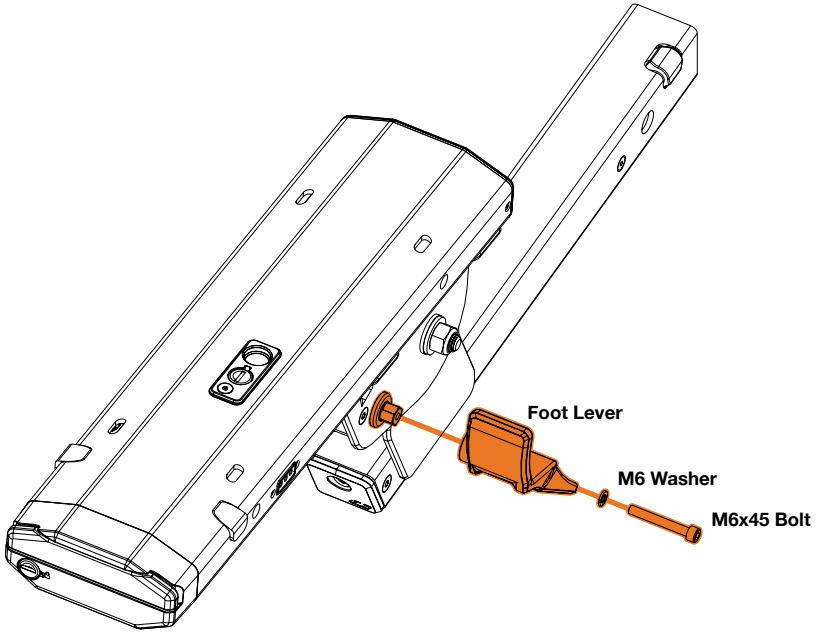

Tighten M6x45 bolt to 15Nm.

Tray Assembly - Part 1

- 1 Each Piston™ tire tray features an EasyClip™ tab that will hook into a slot on the centerbeam, allowing the tire tray to hang in place during assembly.

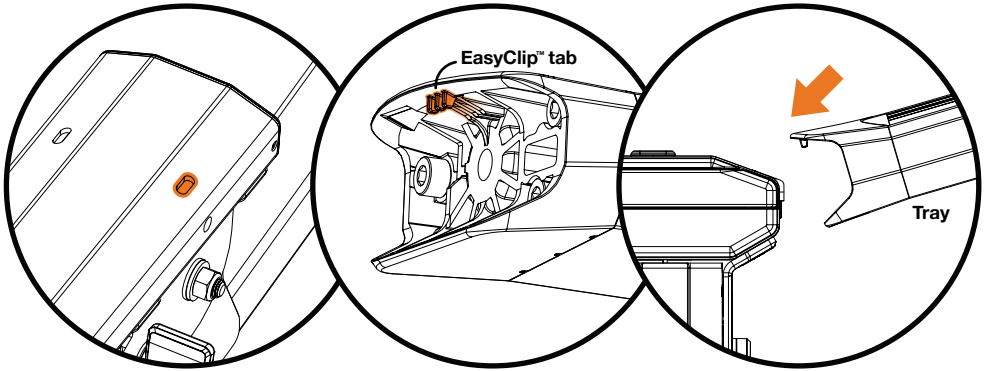

! Angle tire tray to help guide tab as it clips into slot.

Tray Assembly - Expanded View

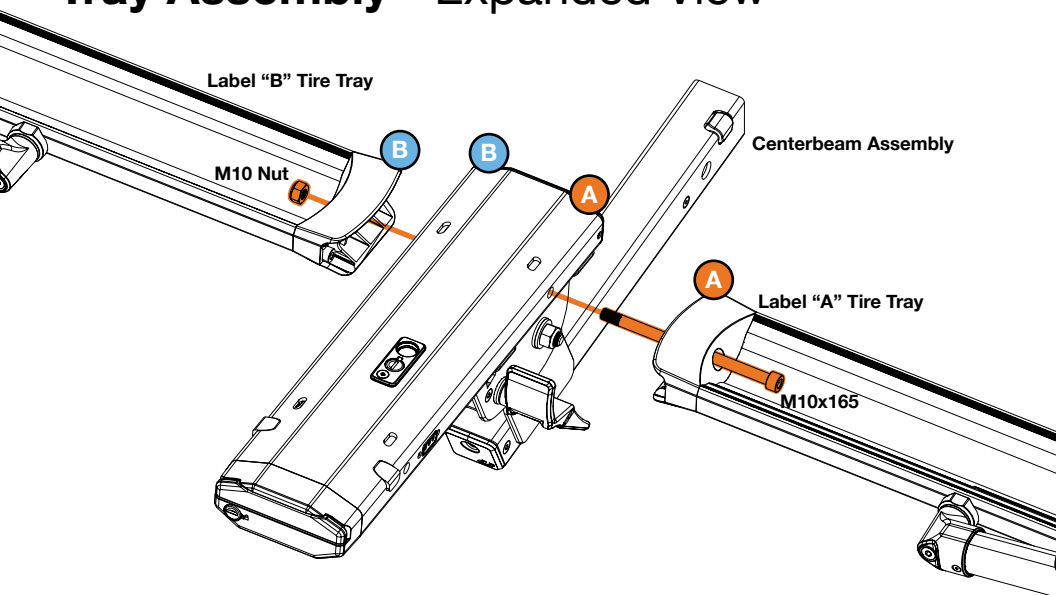

- 2 Hook labeled **A** tray to **A** position on centerbeam.
Hook labeled **B** tray to **B** position on centerbeam.

OneTap™ Operation

Deploying Piston™ arms provides easier access to tray bolt and tray nut locations.

- 1 Your Piston™ arrived with security tabs beneath each OneTap™ lever to ensure safe shipping. Pull each tab upward to remove them and operate the lever.

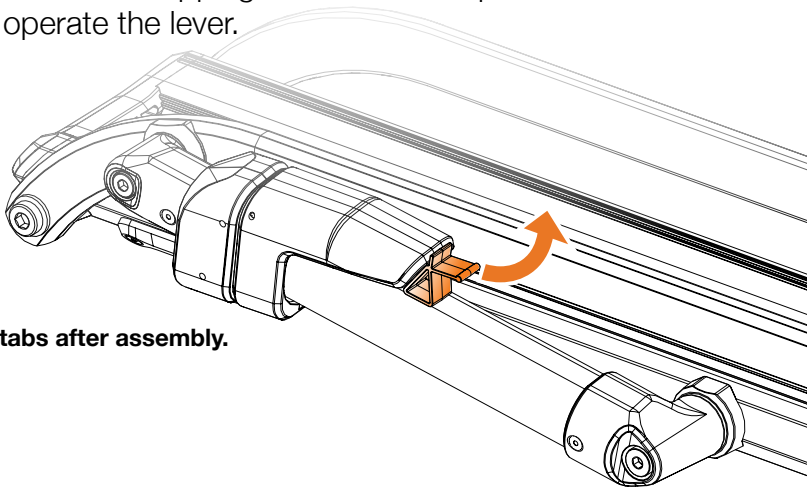

! Dispose of tabs after assembly.

- 2 Open each arm by tapping the OneTap™ levers.
Do not hold the lever down when opening or closing.

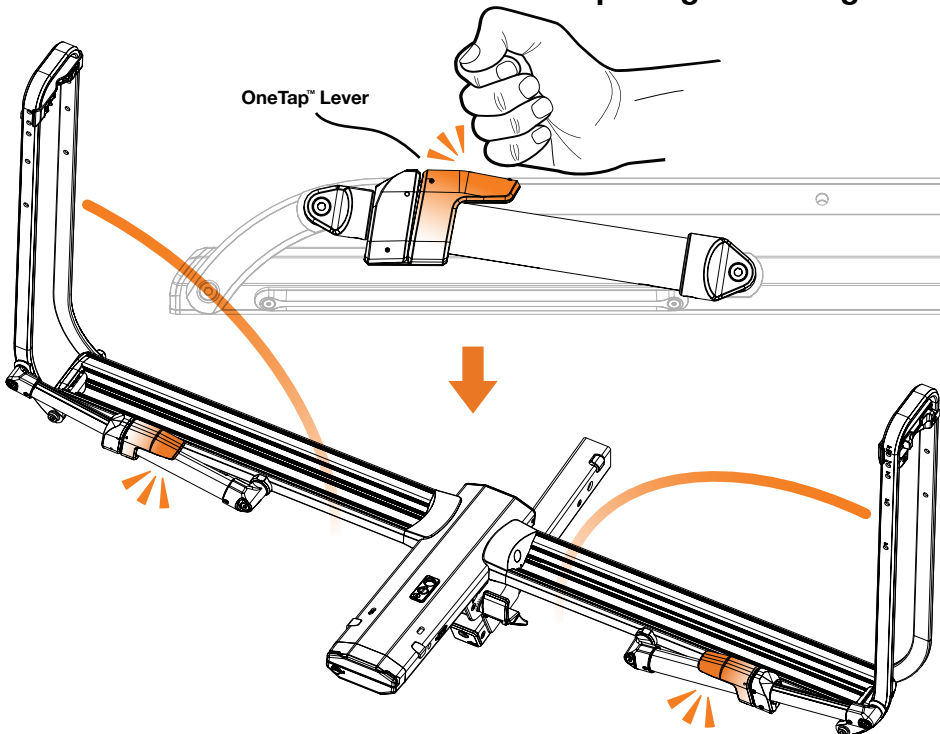

Tray Assembly - Part 2

- 1 Opening Piston™ arms provides easier access to tray bolt and tray nut locations.
- 2 With trays secured, insert M10 nut into **B** tray.

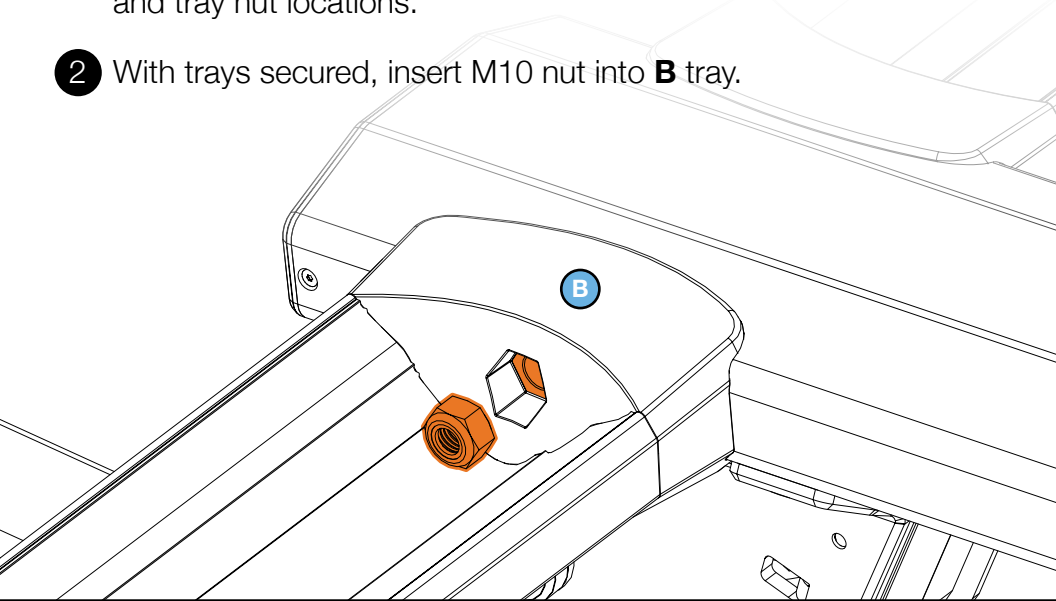

- 3 With M10 nut in place, insert M10x165 into **A** tray, through centerbeam, and into M10 Nut. Tighten with 8mm hex key. (Recommended torque to **40-50Nm - Do not exceed 50Nm**)

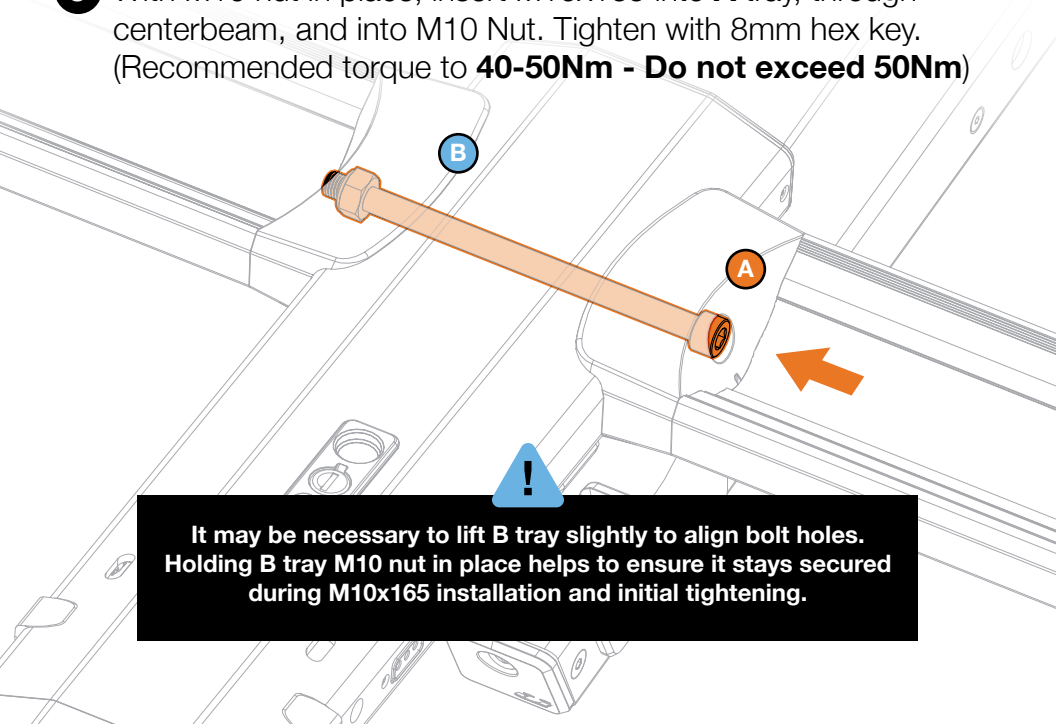

It may be necessary to lift B tray slightly to align bolt holes. Holding B tray M10 nut in place helps to ensure it stays secured during M10x165 installation and initial tightening.

- 4 Hook labeled **C** tray to **C** position on centerbeam.
Hook labeled **D** tray to **D** position on centerbeam.

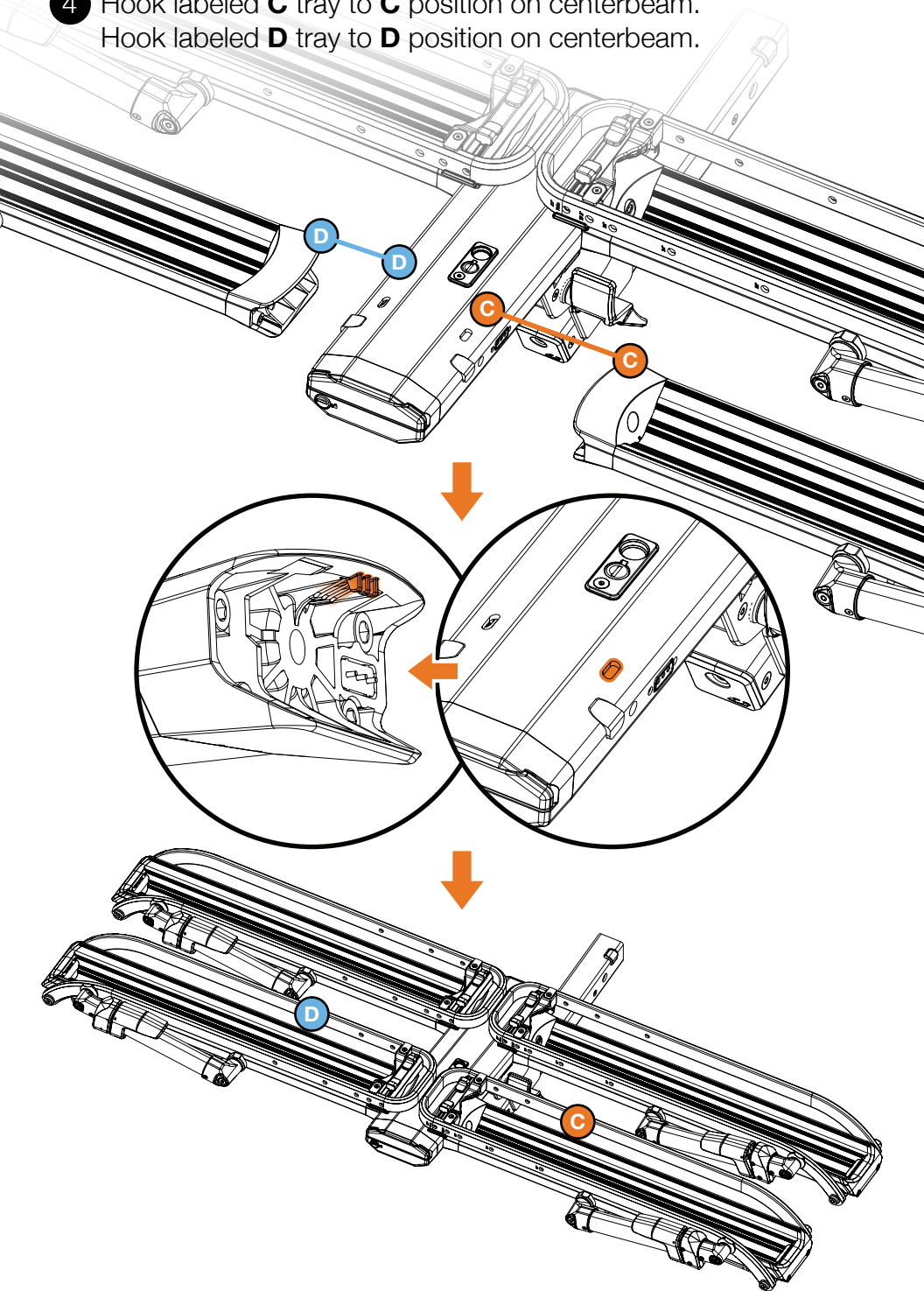

- 5 Opening Piston™ arms provides easier access to tray bolt and tray nut locations.
- 6 With **C** and **D** trays secured, insert M10 nut into **D** tray.

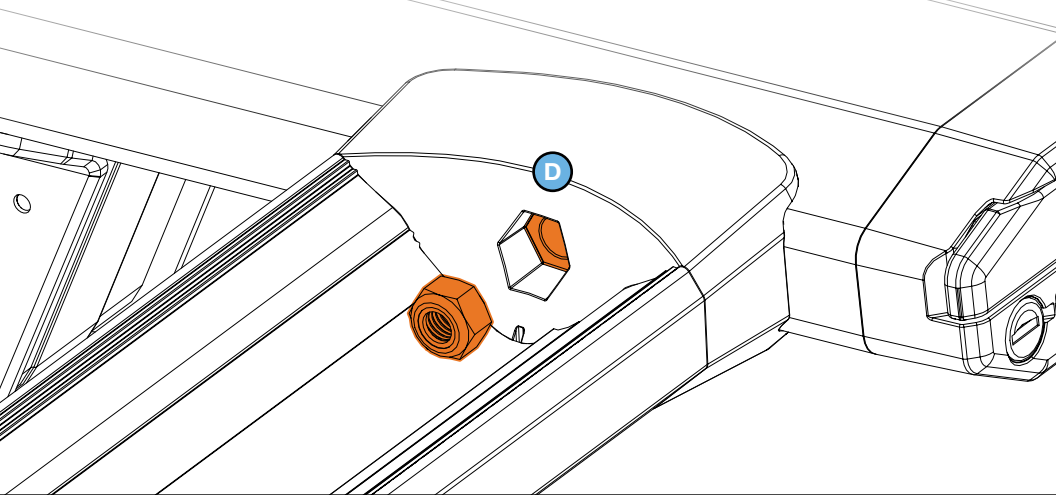

- 7 With M10 nut in place, insert M10x165 into **C** tray, through centerbeam, and into M10 nut. Tighten with 8mm hex key. (Recommended torque to **40-50Nm - Do not exceed 50Nm**)

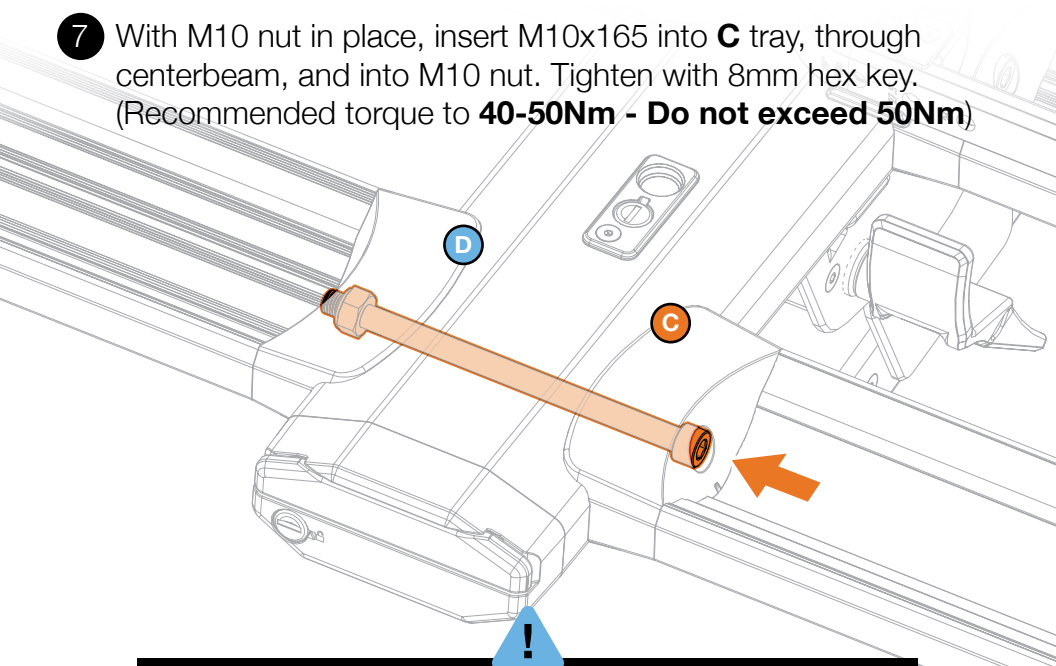

It may be necessary to lift **D** tray slightly to align bolt holes. Holding **D** tray M10 nut in place helps to ensure it stays secured during M10x165 installation and initial tightening.

Hitch Installation

- 1 Insert Piston™ into hitch receiver.

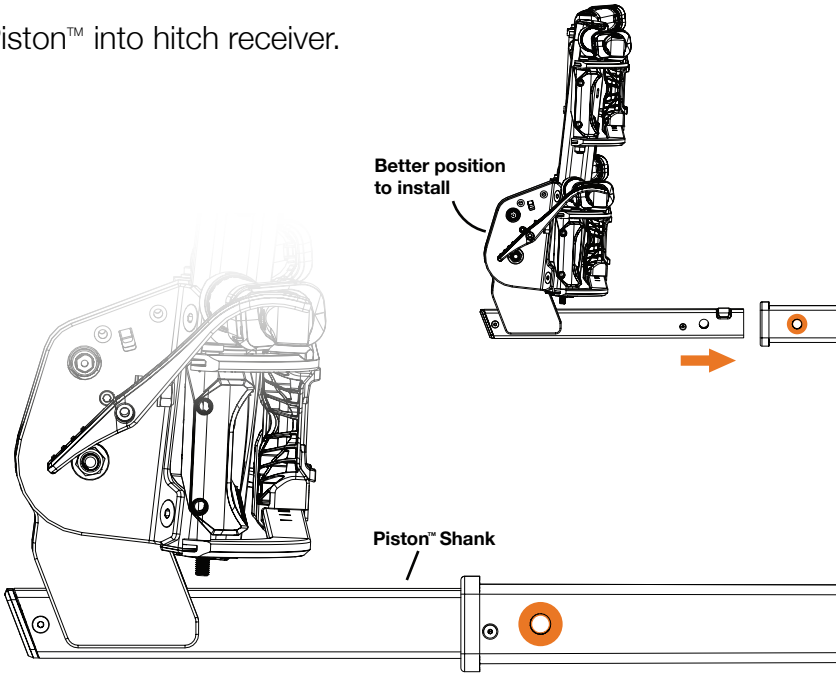

- 2 Align hitch pin holes.

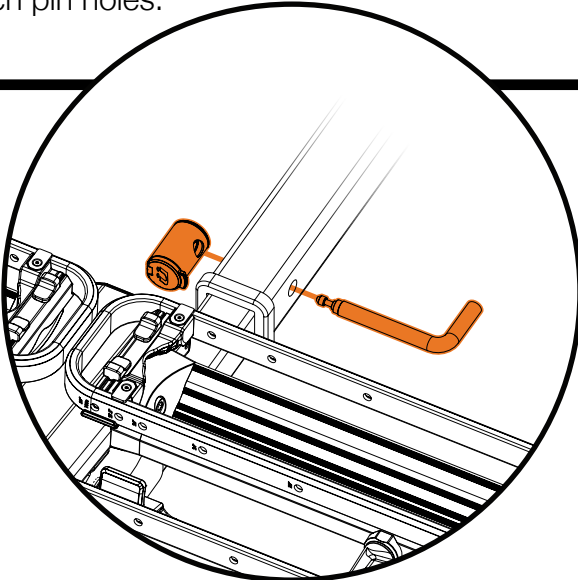

- 3 Insert hitch pin through holes in hitch receiver and Piston™ shank, and secure with hitch pin lock.

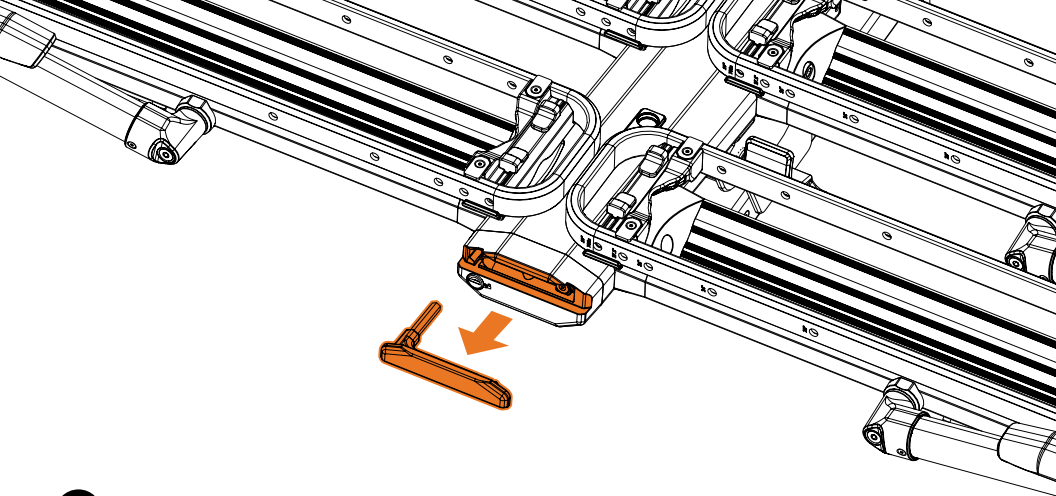

- 4 Unlock and remove the 8mm security hex key found at the front of the centerbeam.

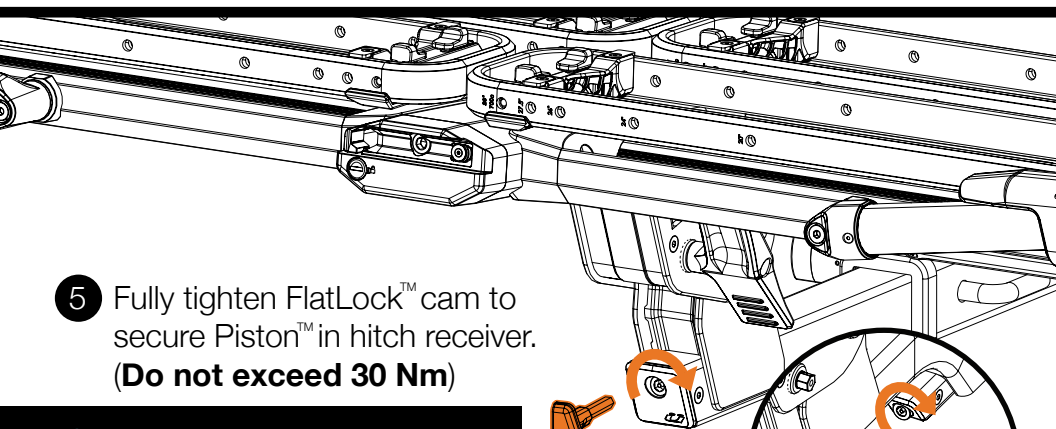

- 5 Fully tighten FlatLock™ cam to secure Piston™ in hitch receiver.
(Do not exceed 30 Nm)

 Remember to reinstall and secure security hex key with key.

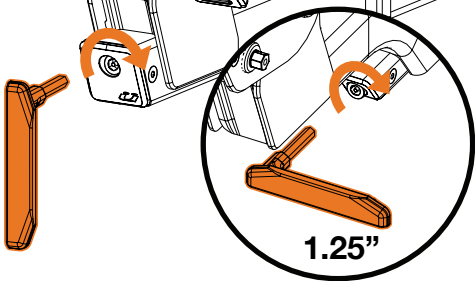

LED Light Installation

- 1 Locate flat 4-pin magnetic cable in your provided parts bag.

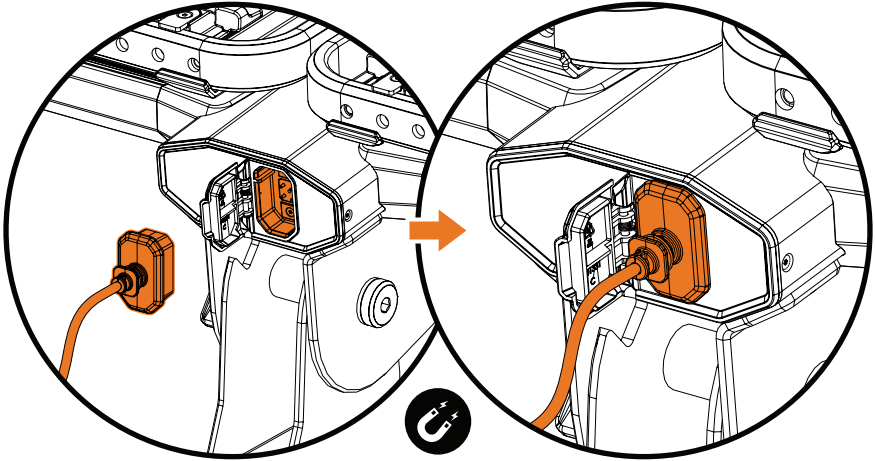

- 2 Plug cable into the hatch located in the rear face of Piston™ centerbeam.

! Cable will snap into outlet and secure itself magnetically.

- 3 Plug flat 4-pin into trailer light socket on your vehicle.

! Your trailer light socket may differ from the model shown - an adapter may be required.

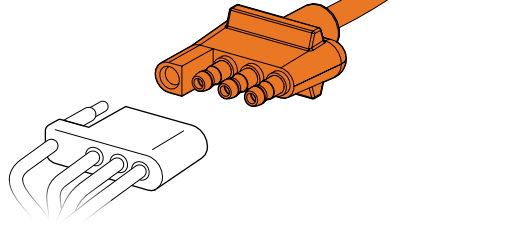

- 4 Perform a test for LED illumination and brake function as well as left and right blinker operation.

! LED lights are inspected and tested prior to packaging. Troubleshoot any issues with your vehicle connections or fuses by visiting kuat.com/piston/led

Cable Management

- 1 Locate (2) magnetic clips in your provided parts bag.

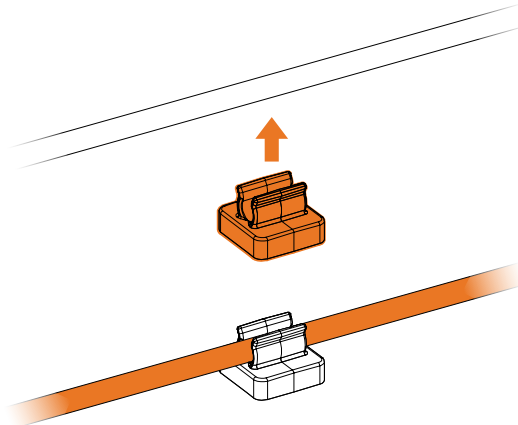

- 2 Place magnets along cable and snap them to the hitch shank and vehicle hitch.

Feel free to adjust magnetic clips up or down the cable to achieve a fit that works best for your setup.

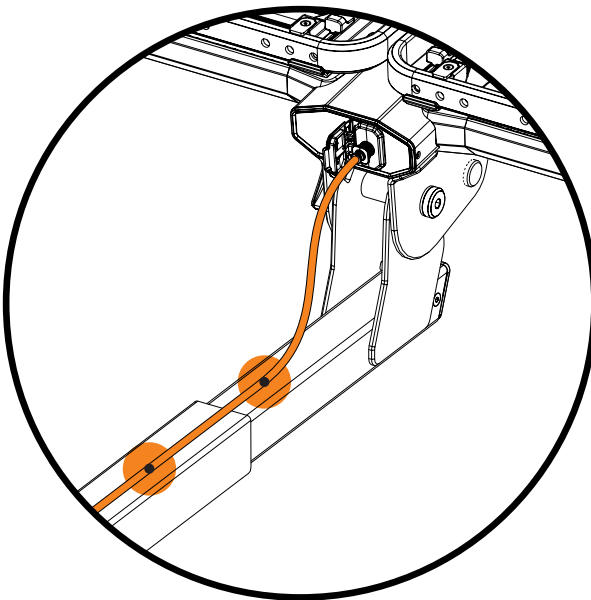

OneTap™ Operation

- 1 Open each arm by tapping the OneTap™ levers. Stand back and watch! Each arm will fully open automatically. **Do not hold the lever while opening or closing.**

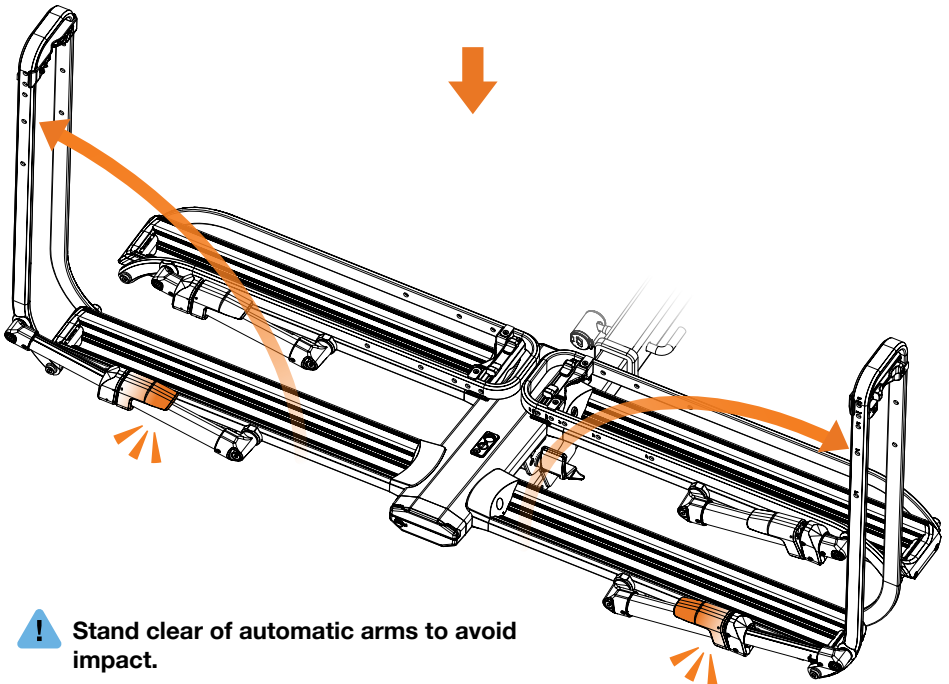
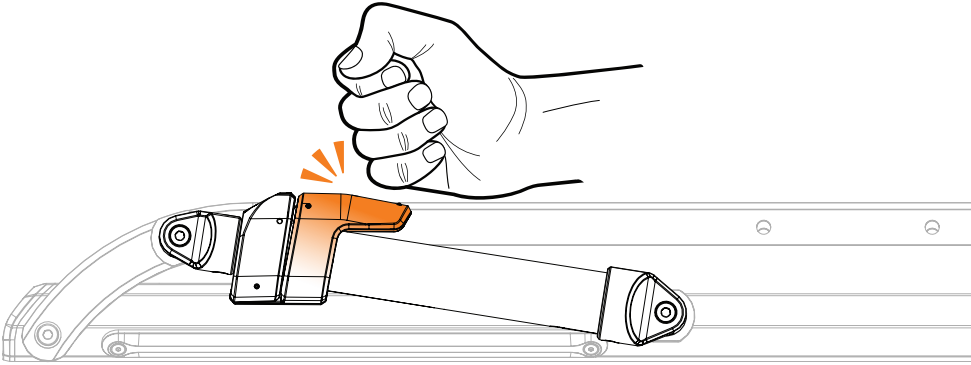

! Stand clear of automatic arms to avoid impact.

- 2 To close, simply push arms back down into stowed position.

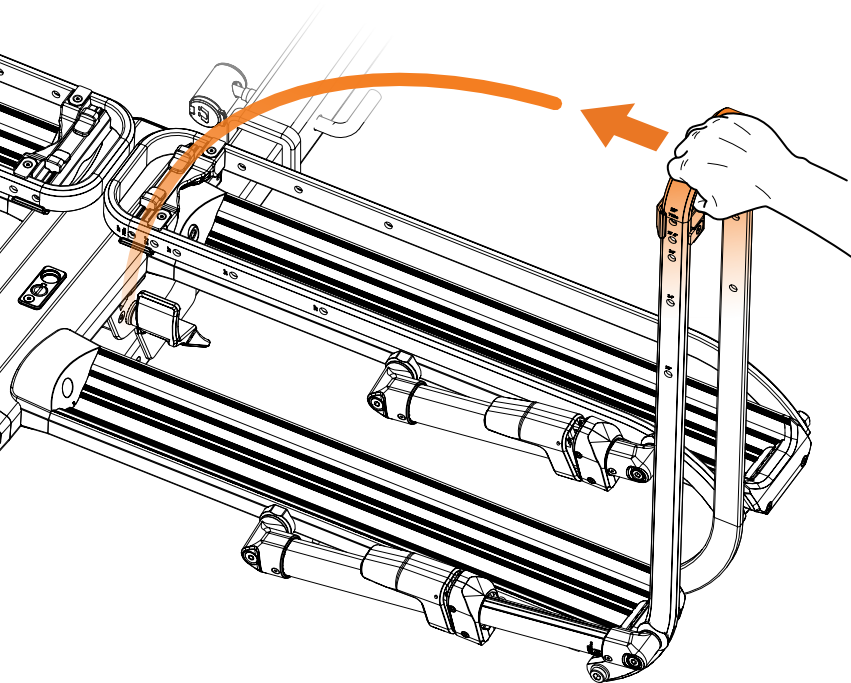

Foot Lever Operation

- 1 Fold rack up and down using the pivot lever.

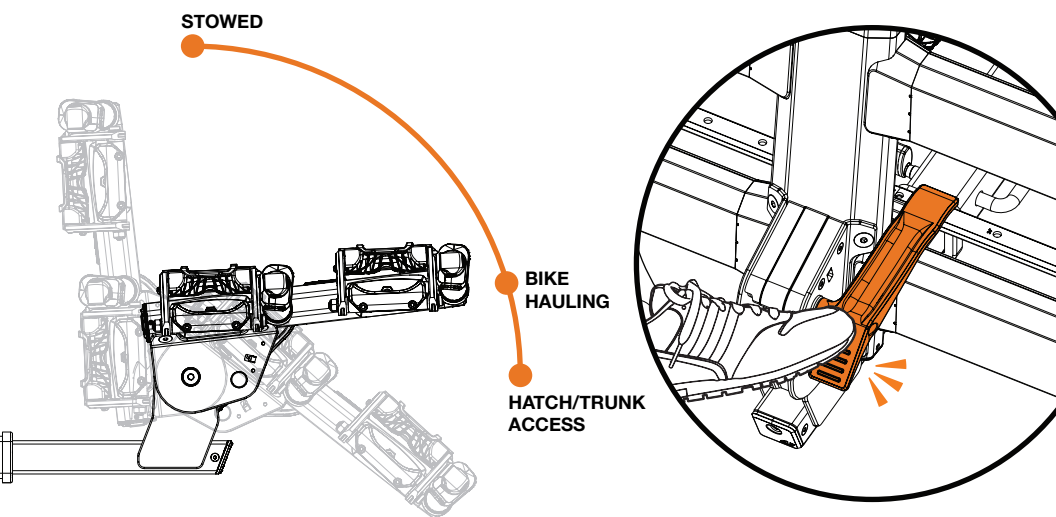

Loading | Unloading Bikes

- 1 Push tabs inward and slide tire cradle up or down tire arm to adjust for measured wheel size.

! How to measure wheel.

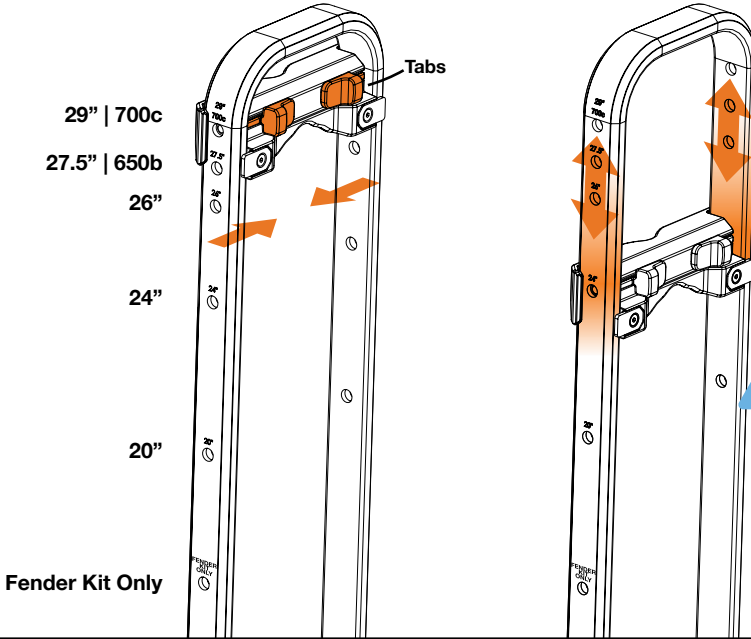
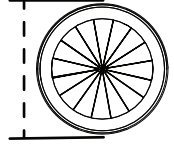

! Scan QR to order Fender Kit.



- 2 Visually ensure tabs are fully secured in notches. Misaligned tabs or tabs not fully secured will show a red warning indicator.

! Failure to secure both tabs may result in bikes becoming loose and falling during travel.

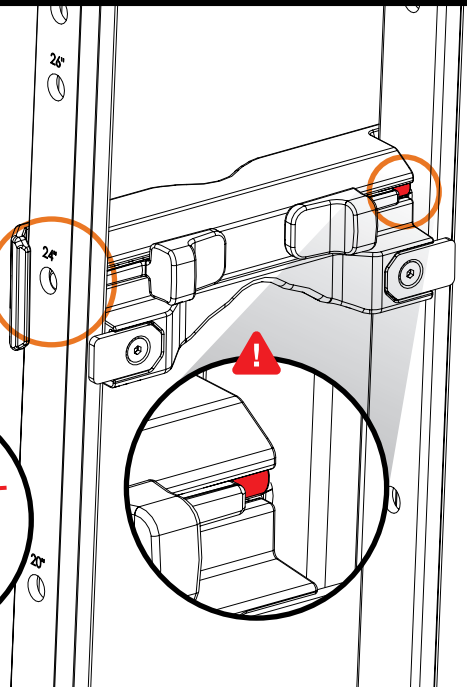
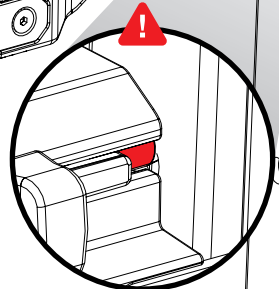
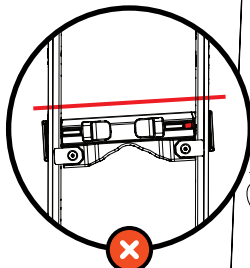
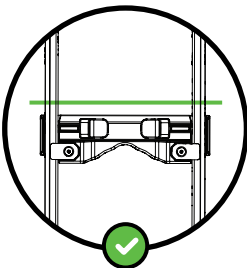

- 3 Open Piston™ tire cradle arms by tapping each OneTap™ lever.

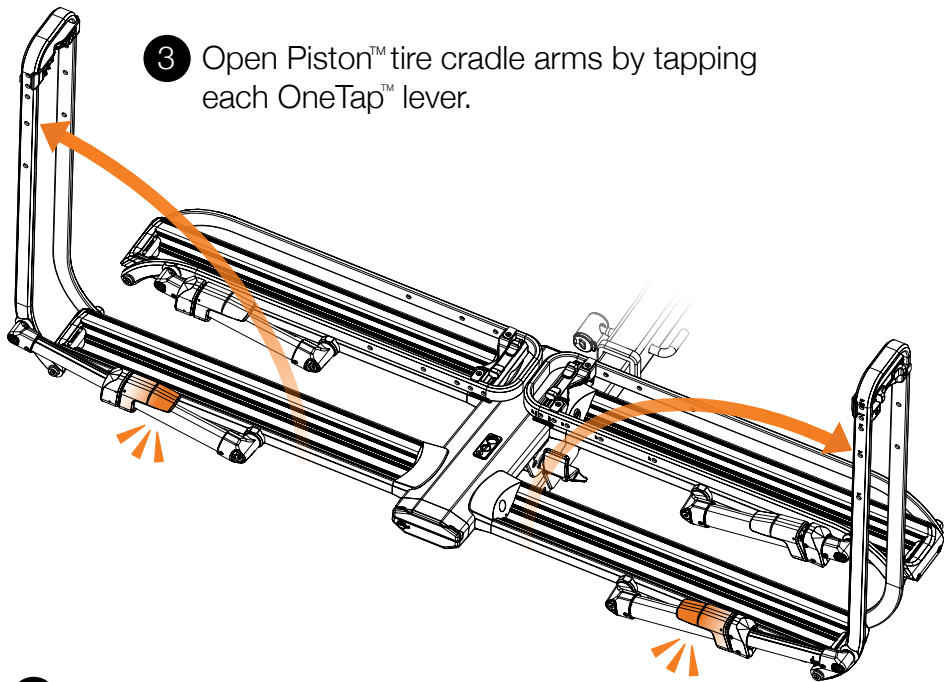

- 4 With bike in position close arms onto tires until firm contact is made with tire cradles.

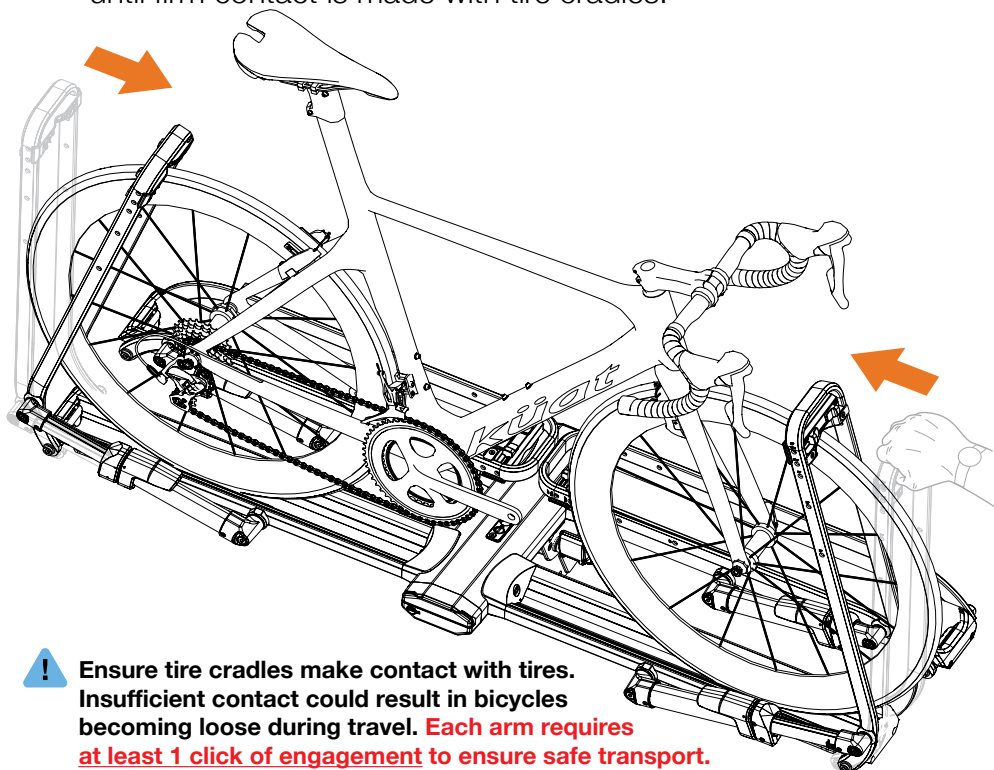

! Ensure tire cradles make contact with tires. Insufficient contact could result in bicycles becoming loose during travel. **Each arm requires at least 1 click of engagement to ensure safe transport.**

- 5 Should the need arise, bikes can be loaded asymmetrically, or oriented in the same direction to accommodate different fitment problems.

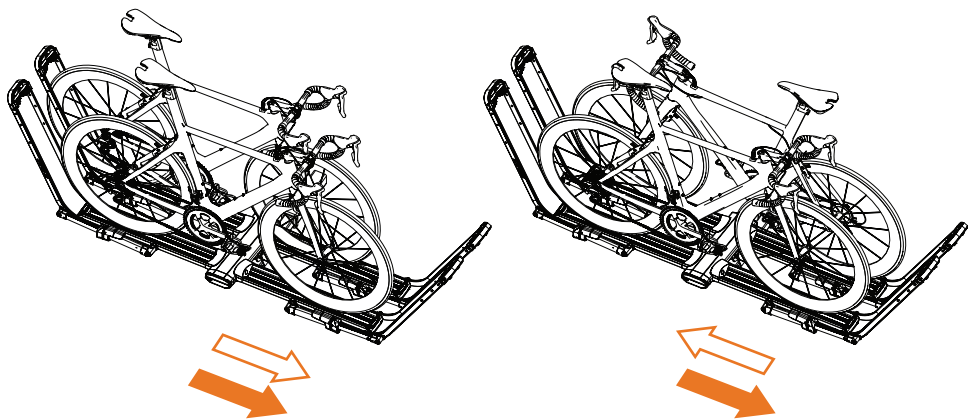

- 6 To further fine tune the fitment, bikes can be adjusted left and right on their individual trays.

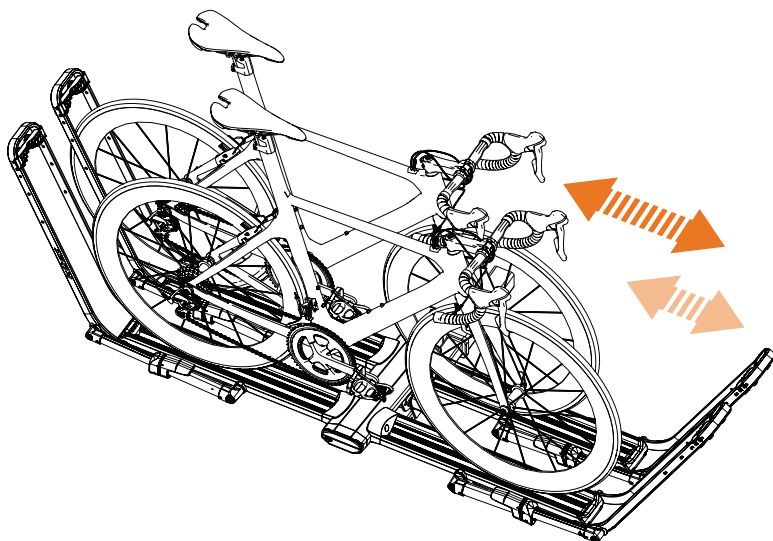

! Ensure tire cradles make contact with tires. Insufficient contact could result in bicycles becoming loose during travel.
Each arm requires **at least 1 click of engagement** to ensure safe transport.

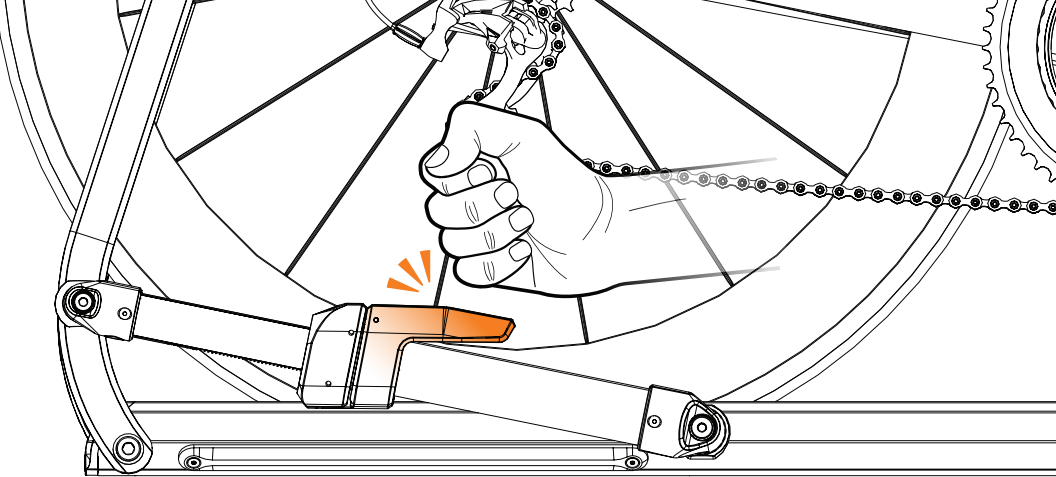

- 7 Tap each OneTap™ lever to release tire arms and unload bike.

! After pushing the OneTap™ lever, it may be necessary to push the tire arm up off the tire.

Securing Your Bikes with Cable Lock

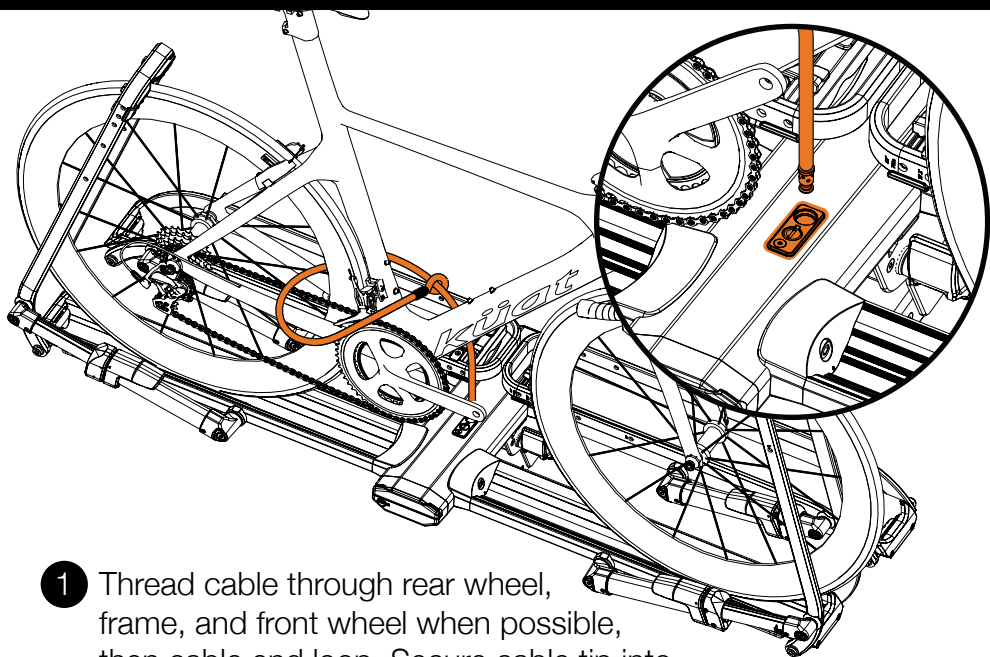

- 1 Thread cable through rear wheel, frame, and front wheel when possible, then cable end loop. Secure cable tip into lock port located on Piston™ centerbeam.

eBike Ramp | Selective Bike Unloading

(Sold Separately)

The Piston™ OneTap™ system allows users to rotate tire arms into a negative position for the installation of the Piston™ eBike Ramp, or conveniently unload a bike in tray 2 without needing to unload tray 1.

To Fold Down

- 1 Tap OneTap™ lever to open tire arm.
 - 2 Pull arm down into negative position.
- ! Do not hold OneTap™ lever while pulling arm into negative position.
- 3 Unload selected bike or install eBike Ramp.
(Sold Separately)

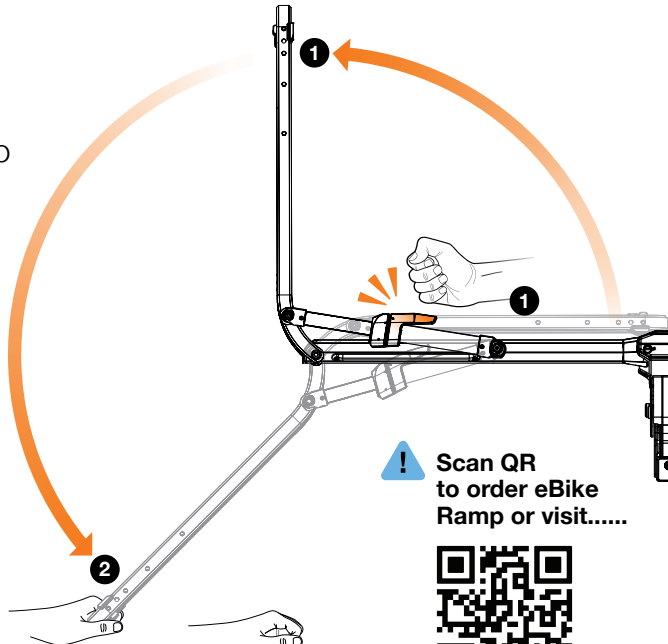

To Fold Up

- 1 Tap OneTap™ lever to release ratchet tension.
 - 2 Pull tire arm back up into towing, or stowed position.
- ! Do not hold OneTap™ lever while moving arm into position.

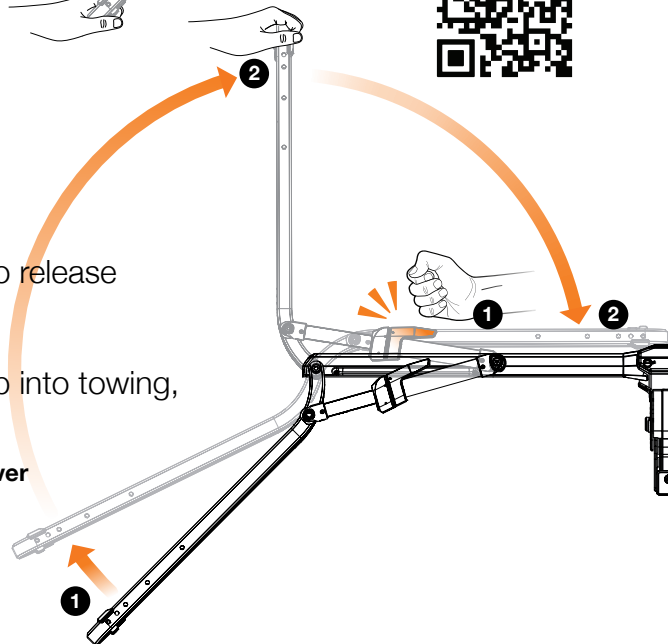

Warnings

PISTON™ PRO X

Number Of Bikes

2

Weight Per Bike
Dedicated 2" Hitch

67 lb

30.4kg

Weight Per Bike
RV use(2" only)

42 lb

19kg

Weight Per Bike
1.25" Hitch Version

60 lb

27.2kg

No RV use

Max Wheelbase

53 in

1346 mm

Max Tire Width

5 in

127 mm

WARNINGS

- Follow instructions for proper assembly, installation and use.
- Check tightness of all bolts and screws periodically.
- Make sure rack and vehicle receiver are in working condition before each use.
- Only use Küat hitch extenders with this product.
- Do not use bicycle fenders with this product without Piston™ Fender Kit.
- Do not exceed the bicycle or weight limits intended for this rack.
- Do not use rack off road (rough, washed out, boulder-and-rut-strewn backroads).
-Smooth gravel roads are not considered off-road.
- Do not install this product on campers, recreational vehicles or trailers.
2" hitch Piston™ in the 2 bike configuration may be used on **chassis mounted hitches**.
- Do not use tarps, rain covers or wind covers with this product.
- Do not take through automatic car wash.
- Drive responsibly.

If you have questions or problems, please contact Küat Racks directly by calling toll free 1(877)822-KUAT, or by email: info@kuat.com

ADVERTENCIAS

- Siga las instrucciones para un montaje, instalación y uso adecuados.
- Compruebe periódicamente la estanqueidad de todos los pernos y tornillos.
- Asegúrese de que el estante y el receptor del vehículo estén en buena condición antes de cada uso.
- Utilice únicamente extensores de enganche Küat con este producto.
- No utilice guardafangos delanteros para bicicletas con este producto.
- No exceda los límites de bicicleta o peso destinados a esta parrilla.
- No utilice el bastidor Off-Road *. (* Caminos en bruto, deslavados, llenos de rocas y surcos).
-Los caminos de grava lisa no se consideran fuera de carretera.
- No instale este producto en caravanas, vehículos recreativos o remolques.
-Enganche de -2 "El pistón en la configuración de 2 bicicletas se puede usar en los enganches montados en el chasis.
- No use lonas, cubiertas para la lluvia o cubiertas para el viento con este producto.
- No usar en el lavado automático de automóviles.
- Conduzca responsablemente.

AVERTISSEMENTS

- Suivez les instructions pour un assemblage, une installation et une utilisation appropriés.
- Vérifiez régulièrement le serrage de tous les boulons et vis.
- Assurez-vous que le support et le récepteur du véhicule sont en état de marche avant chaque utilisation.
- Utilisez uniquement des rallonges d'attelage Küat avec ce produit.
- N'utilisez pas d'ailes de vélo avant avec ce produit.
- Ne dépassez pas les limites de vélo ou de poids prévues pour ce support.
- N'utilisez pas le rack Off-Road *. (* Routes rugueuses, délavées, parsemées de rochers et d'ornières).
-Les routes de gravier lisses ne sont pas considérées comme hors route.
- N'installez pas ce produit sur des camping-cars, des véhicules récréatifs ou des remorques.
-Le piston d'attelage de 2 po dans la configuration à 2 vélos peut être utilisé sur les attelages montés sur le châssis.
- N'utilisez pas de bâches, de housses de pluie ou de vent avec ce produit.
- Ne passez pas au lave-auto automatique.
- Conduisez de manière responsable.

Küat Innovations LLC. Limited Lifetime Warranty

Küat honors the warranty on all Küat brand products for original owners of the product. Warranty is not transferable.

If a Küat rack that is covered by the terms of this warranty and is determined by Küat, to be defective, Küat will repair or replace the defective parts. Küat may choose in some cases to offer the owner a refund of up to the original purchase price of the product in lieu of repairing or replacing the product.

The Küat Warranty does not cover any conditions that are beyond Küat's control. This includes, but is not limited to, the following: excessive loading, improper assembly, improper installation, theft, or any use that is not consistent with the user guide that is included with the product.

The Küat Warranty does not cover normal wear and tear, scratches, cosmetic oxidation, accidents, or damage due to unauthorized repairs or modifications.

If you are the original owner of a defective Küat product, please contact Küat at 1(877)822-5828. A Küat representative will work to quickly resolve the problem. If repairs are necessary, the owner will be responsible for the cost of returning the product to Küat for repair. No product should be returned to Küat without prior authorization from Küat staff.

LIMIT OF LIABILITY

THIS WARRANTY ONLY COVERS REPAIR, REPLACEMENT OR REFUND FOR THE COVERED KÜAT PRODUCT. ANY DAMAGE TO VEHICLE OR PROPERTY IS NOT COVERED BY THIS WARRANTY. PERSONAL INJURY IS NOT COVERED BY THIS WARRANTY.

LIMITATION OR EXCLUSION OF INCIDENTAL DAMAGE IS NOT ALLOWED IN ALL STATES SO THE ABOVE LIMITATIONS MAY NOT APPLY.

Küat respeta la garantía de todos los portabicicletas Küat mientras el comprador original sea el propietario de dicho producto. Si el comprador original vende o de alguna otra manera cede el producto a otra persona, la garantía será revocada.

Si un portabicicletas Küat que esté cubierto por los términos de esta garantía está defectuoso, Küat reparará o reemplazará las partes defectuosas a su propio criterio. Küat puede optar en algunos casos por ofrecer el reembolso del precio de compra del producto en lugar de repararlo o de reemplazar las piezas defectuosas.

La garantía Küat no cubre ninguna condición que esté más allá del control de Küat. Esto incluye, más no limita, carga excesiva, ensamblaje impropio, montaje impropio, robo o cualquier uso que no sea consistente con las instrucciones que están incluidas con el producto o que están disponibles para el usuario.

La garantía Küat no cubre el uso y desgaste natural, raspaduras, oxidación cosmética, accidentes, operación ilegal del vehículo o modificaciones o reparaciones no autorizadas.

Si usted es el propietario original de un producto Küat defectuoso, por favor contacte a Küat al 1(877) 822-5828. Un representante de Küat le atenderá para resolver su problema. Si son necesarias reparaciones, el propietario será responsable por el costo del envío del producto a Küat para su reparación. Ningún producto deberá ser enviado a Küat sin previa autorización de un agente de Küat.

LIMITE DE RESPONSABILIDAD

ESTA GARANTIA SOLO CUBRE REPARACIONES, REEMPLAZOS O REEMBOLSOS PARA EL PRODUCTO DE KÜAT CUBIERTO. CUALQUIER DAÑO AL VEHICULO O PROPIEDAD O LESION NO ESTA CUBIERTA POR ESTA GARANTIA.

LIMITANTES O EXCLUSIONES DE DAÑO ACCIDENTAL NO ESTAN PERMITIDAS EN TODOS LOS ESTADOS, POR LO TANTO ESTAS LIMITANTES PODRIAN NO APLICAR.

Küat honore la garantie de toute sa gamme du support de la marque Küat tant qu'il demeure la propriété du propriétaire original. La garantie prend fin lorsque le propriétaire original se départit du produit en le vendant ou en le transférant à une autre personne.

Si un article Küat fait défaut alors qu'il est sous garantie, Küat réparera ou remplacera, à sa discrétion, la ou les pièces défectueuses. Küat pourrait choisir dans certains cas d'offrir un remboursement du prix à l'achat au lieu de réparer ou de remplacer la pièce défectueuse.

La garantie Küat ne couvre pas les conditions hors du contrôle de Küat. Celles-ci incluent mais ne sont pas limitées à un chargement excessif, un assemblage erroné, un mauvais montage, le vol ou tout usage qui n'est pas conforme aux instructions (incluses avec le produit) accessibles à l'utilisateur.

La garantie Küat ne couvre pas l'usure normale, les égratignures, l'oxydation, les accidents, l'usage illégal d'un véhicule ou les réparations ou modifications non-autorisées.

Si vous êtes le propriétaire original d'un produit Küat défectueux, prière de contacter Küat au 1-877-822-5828. Un représentant Küat travaillera à la résolution du problème. Si des réparations sont nécessaires, l'acheteur doit assumer les frais d'envoi pour faire parvenir le produit Küat à l'entreprise. Ne retourner pas un produit Küat tant que vous n'obtenez pas l'autorisation d'un représentant de Küat.

LIMITE DE RESPONSABILITÉS

LA GARANTIE COUVRE SEULEMENT LA RÉPARATION, LE REMPLACEMENT OU LE REMBOURSEMENT D'UN PRODUIT KÜAT SOUS GARANTIE. LA GARANTIE NE COUVRE PAS LES DOMMAGES AU VÉHICULE, LES DOMMAGES À LA PROPRIÉTÉ NI LES BLESSURES.

LES RESTRICTIONS OU LES EXCLUSIONS CONCERNANT LES DOMMAGES ACCIDENTELLES NE SONT PAS ADMISES DANS TOUS LES ÉTATS OU CES RESTRICTIONS PEUVENT NE PAS S'APPLIQUER.

Notes:

kuat[®]

1.877.822.5828
info@kuat.com
kuat.com